

Weld End Fittings

45° Bends, BS4825-2

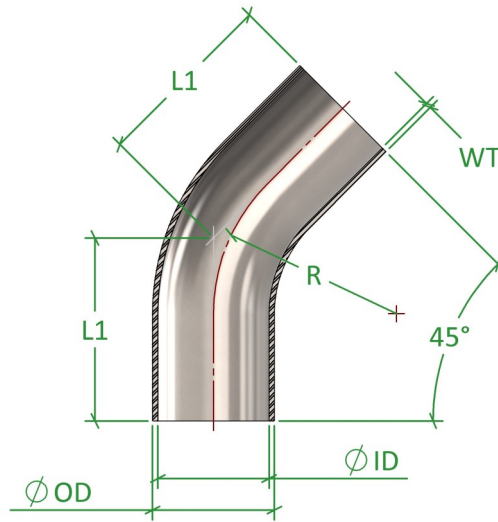

Standard	BS4825-2	Certification	EN10204 3.1
Connections	Weld Ended	Associated Parts	Tube BS4825-1, Fittings BS4825-2, TC BS4825-3
Material	316L Stainless Steel EN 1.4404	Associated Standards	BS4825-1, BS4825-2, BS4825-3, ASME BPE
Surface Finish	Dull Polish	Options	Non Standard Sizes, Duplex Materials
Remarks	* Not Referenced Directly In Standard, but Accepted Within The Industry as "Standard"		

Weld End Fittings, BS4825-2, 45° Bends

Size (inch)	TUBE OD (mm)	TUBE ID (mm)	WT (mm)	R (mm)	L1 (mm)	Part Code
*0.500"	12.70	9.40	1.65	28.60	30.2	W45.BS.0050.6P
*0.750"	19.05	15.75	1.65	28.60	30.2	W45.BS.0075.6P
*1.000"	25.40	22.10	1.65	38.10	30.2	W45.BS.0100.6P
*1.500"	38.10	34.80	1.65	57.15	41.3	W45.BS.0150.6P
*2.000"	50.80	47.50	1.65	76.20	58.70	W45.BS.0200.6P
*2.500"	63.50	60.20	1.65	95.25	76.20	W45.BS.0250.6P
*3.000"	76.20	72.00	1.65	114.30	93.70	W45.BS.0300.6P
*4.000"	101.60	97.60	2.00	152.40	122.20	W45.BS.0400.6P

Published Data Is Given in Good Faith. We Reserve the Right To, Without Warning Change the Dimensions When Not In Conflict With The Published Standard

Flowsource Process Fittings Ltd

Unit 4 Marrtree Business Park, Cedar Road, Sowerby, Thirsk, North Yorkshire, YO7 3FF, United Kingdom
 [T] 01535 274 316 - [e] sales@flowsourcepf.com - [w] www.flowsourcepf.com

FLOWSOURCE
PROCESS FITTINGS