

Weld End Fittings

Equal Tees, BS4825-2, Short & Long

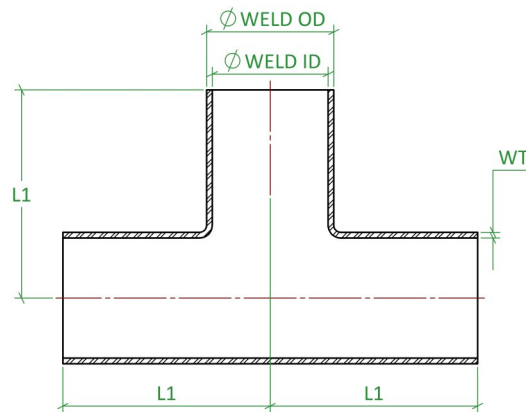
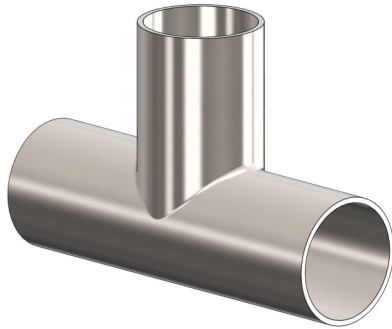
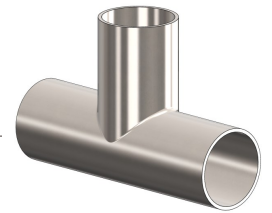

Standard	BS4825-2	Certification	EN10204 3.1
Connections	Weld Ended	Associated Parts	Tube BS4825-1, Fittings BS4825-2, TC BS4825-3
Material	316L Stainless Steel EN 1.4404	Associated Standards	BS4825-1, BS4825-2, BS4825-3, ASME BPE
Surface Finish	Dull Polish	Options	Descaled, Non Standard Sizes, Duplex Materials
Remarks	* Not Referenced Directly In Standard, but Accepted Within The Industry as "Standard"		

Weld End Fittings, BS4825-2, Equal Tee, Short Version

Size (inch)	TUBE OD (mm)	TUBE ID (mm)	WT (mm)	L1 (mm)	Part Code
1.000"	25.40	22.10	1.65	43.50	WTE.BSS.0100.6P
1.500"	38.10	34.80	1.65	63.50	WTE.BSS.0150.6P
2.000"	50.80	47.50	1.65	88.50	WTE.BSS.0200.6P
2.500"	63.50	60.20	1.65	113.50	WTE.BSS.0250.6P
3.000"	76.20	72.90	1.65	133.50	WTE.BSS.0300.6P
4.000"	101.60	97.60	2.00	173.50	WTE.BSS.0400.6P

Weld End Fittings, BS4825-2, Equal Tee, Long Version

Size (inch)	TUBE OD (mm)	TUBE ID (mm)	WT (mm)	L1 (mm)	Part Code
0.500"	12.70	9.40	1.65	60.00	WTE.BSL.0050.6P
0.750"	19.05	15.75	1.65	60.00	WTE.BSL.0075.6P
1.000"	25.40	22.10	1.65	65.00	WTE.BSL.0100.6P
1.500"	38.10	34.80	1.65	85.00	WTE.BSL.0150.6P
2.000"	50.80	47.50	1.65	110.00	WTE.BSL.0200.6P
2.500"	63.50	60.20	1.65	135.00	WTE.BSL.0250.6P
3.000"	76.20	72.90	1.65	155.00	WTE.BSL.0300.6P
4.000"	101.60	97.60	2.00	195.00	WTE.BSL.0400.6P
4.500"	114.30	110.30	2.00	210.00	WTE.BSL.0450.6P
5.500"	139.70	135.70	2.00	250.00	WTE.BSL.0550.6P
6.580"	168.30	163.10	2.60	295.00	WTE.BSL.0658.6P
8.580"	219.10	213.90	2.60	370.00	WTE.BSL.0858.6P

Published Data Is Given in Good Faith. We Reserve the Right To, Without Warning Change the Dimensions When Not In Conflict With The Published Standard

Flowsource Process Fittings Ltd

Unit 4 Marrtree Business Park, Cedar Road, Sowerby, Thirsk, North Yorkshire, YO7 3FF, United Kingdom
 [T] 01535 274 316 - [e] sales@flowsourcepf.com - [w] www.flowsourcepf.com

FLOWSOURCE
PROCESS FITTINGS